

PHILIPPINE BIDDING DOCUMENTS

**Procurement of
INFRASTRUCTURE
PROJECTS**

Government of the Republic of the Philippines

**CONSTRUCTION OF BOX CULVERT / RC PIPE CULVERT
AT BARANGAY PARANGOPONG
CITY OF BATAAC, ILOCOS NORTE**

**Sixth Edition
July 2020**

Preface

These Philippine Bidding Documents (PBDs) for the procurement of Infrastructure Projects (hereinafter referred to also as the “Works”) through Competitive Bidding have been prepared by the Government of the Philippines for use by all branches, agencies, departments, bureaus, offices, or instrumentalities of the government, including government-owned and/or -controlled corporations, government financial institutions, state universities and colleges, local government units, and autonomous regional government. The procedures and practices presented in this document have been developed through broad experience, and are for mandatory use in projects that are financed in whole or in part by the Government of the Philippines or any foreign government/foreign or international financing institution in accordance with the provisions of the 2016 revised Implementing Rules and Regulations (IRR) of Republic Act (RA) No. 9184.

The PBDs are intended as a model for admeasurements (unit prices or unit rates in a bill of quantities) types of contract, which are the most common in Works contracting.

The Bidding Documents shall clearly and adequately define, among others: (i) the objectives, scope, and expected outputs and/or results of the proposed contract; (ii) the eligibility requirements of Bidders; (iii) the expected contract duration; and (iv) the obligations, duties, and/or functions of the winning Bidder.

Care should be taken to check the relevance of the provisions of the PBDs against the requirements of the specific Works to be procured. If duplication of a subject is inevitable in other sections of the document prepared by the Procuring Entity, care must be exercised to avoid contradictions between clauses dealing with the same matter.

Moreover, each section is prepared with notes intended only as information for the Procuring Entity or the person drafting the Bidding Documents. They shall not be included in the final documents. The following general directions should be observed when using the documents:

- a. All the documents listed in the Table of Contents are normally required for the procurement of Infrastructure Projects. However, they should be adapted as necessary to the circumstances of the particular Project.
- b. Specific details, such as the “Barangay Sumader” and “#24 Sumader, City of Batac, Ilocos Norte,” should be furnished in the Instructions to Bidders, Bid Data Sheet, and Special Conditions of Contract. The final documents should contain neither blank spaces nor options.
- c. This Preface and the footnotes or notes in italics included in the Invitation to Bid, BDS, General Conditions of Contract, Special Conditions of Contract, Specifications, Drawings, and Bill of Quantities are not part of the text of the final document, although they contain instructions that the Procuring Entity should strictly follow.
- d. The cover should be modified as required to identify the Bidding Documents as to the names of the Project, Contract, and Procuring Entity, in addition to date of issue.
- e. Modifications for specific Procurement Project details should be provided in the Special Conditions of Contract as amendments to the Conditions of Contract. For easy completion, whenever reference has to be made to specific clauses in the Bid Data Sheet or Special Conditions of Contract, these terms shall be printed in bold typeface on Sections I (Instructions to Bidders) and III (General Conditions of Contract), respectively.

- f. For guidelines on the use of Bidding Forms and the procurement of Foreign-Assisted Projects, these will be covered by a separate issuance of the Government Procurement Policy Board.

TABLE OF CONTENTS

Glossary of Terms, Abbreviations, and Acronyms	5
Section I. Invitation to Bid.....	8
Section II. Instructions to Bidders	11
1. Scope of Bid.....	12
2. Funding Information	12
3. Bidding Requirements.....	12
4. Corrupt, Fraudulent, Collusive, Coercive, and Obstructive Practices	12
5. Eligible Bidders.....	12
6. Origin of Associated Goods	13
7. Subcontracts	13
8. Pre-Bid Conference.....	13
9. Clarification and Amendment of Bidding Documents	13
10. Documents Comprising the Bid: Eligibility and Technical Components	13
11. Documents Comprising the Bid: Financial Component	14
12. Alternative Bids	14
13. Bid Prices	14
14. Bid and Payment Currencies	14
15. Bid Security.....	15
16. Sealing and Marking of Bids.....	15
17. Deadline for Submission of Bids	15
18. Opening and Preliminary Examination of Bids	15
19. Detailed Evaluation and Comparison of Bids.....	15
20. Post Qualification.....	16
21. Signing of the Contract	16
Section III. Bid Data Sheet	17
Section IV. General Conditions of Contract.....	19
1. Scope of Contract.....	20
2. Sectional Completion of Works	20
3. Possession of Site.....	20
4. The Contractor's Obligations.....	20
5. Performance Security	20
6. Site Investigation Reports	21
7. Warranty.....	21
8. Liability of the Contractor.....	21
9. Termination for Other Causes.....	21
10. Dayworks	21
11. Program of Work.....	21

12. Instructions, Inspections and Audits	22
13. Advance Payment.....	22
14. Progress Payments	22
15. Operating and Maintenance Manuals.....	22
Section V. Special Conditions of Contract	23
Section VI. Specifications	25
Section VII. Drawings	30
Section VIII. Bill of Quantities.....	36
Section IX. Checklist of Technical and Financial Documents	38

Glossary of Terms, Abbreviations, and Acronyms

ABC – Approved Budget for the Contract.

ARCC – Allowable Range of Contract Cost.

BAC – Bids and Awards Committee.

Bid – A signed offer or proposal to undertake a contract submitted by a bidder in response to and in consonance with the requirements of the bidding documents. Also referred to as *Proposal* and *Tender*. (2016 revised IRR, Section 5[c])

Bidder – Refers to a contractor, manufacturer, supplier, distributor and/or consultant who submits a bid in response to the requirements of the Bidding Documents. (2016 revised IRR, Section 5[d])

Bidding Documents – The documents issued by the Procuring Entity as the bases for bids, furnishing all information necessary for a prospective bidder to prepare a bid for the Goods, Infrastructure Projects, and/or Consulting Services required by the Procuring Entity. (2016 revised IRR, Section 5[e])

BIR – Bureau of Internal Revenue.

BSP – Bangko Sentral ng Pilipinas.

CDA – Cooperative Development Authority.

Consulting Services – Refer to services for Infrastructure Projects and other types of projects or activities of the GOP requiring adequate external technical and professional expertise that are beyond the capability and/or capacity of the GOP to undertake such as, but not limited to: (i) advisory and review services; (ii) pre-investment or feasibility studies; (iii) design; (iv) construction supervision; (v) management and related services; and (vi) other technical services or special studies. (2016 revised IRR, Section 5[i])

Contract – Refers to the agreement entered into between the Procuring Entity and the Supplier or Manufacturer or Distributor or Service Provider for procurement of Goods and Services; Contractor for Procurement of Infrastructure Projects; or Consultant or Consulting Firm for Procurement of Consulting Services; as the case may be, as recorded in the Contract Form signed by the parties, including all attachments and appendices thereto and all documents incorporated by reference therein.

Contractor – is a natural or juridical entity whose proposal was accepted by the Procuring Entity and to whom the Contract to execute the Work was awarded. Contractor as used in these Bidding Documents may likewise refer to a supplier, distributor, manufacturer, or consultant.

CPI – Consumer Price Index.

DOLE – Department of Labor and Employment.

DTI – Department of Trade and Industry.

Foreign-funded Procurement or Foreign-Assisted Project – Refers to procurement whose funding source is from a foreign government, foreign or international financing institution as specified in the Treaty or International or Executive Agreement. (2016 revised IRR, Section 5[b]).

GFI – Government Financial Institution.

GOCC – Government-owned and/or –controlled corporation.

Goods – Refer to all items, supplies, materials and general support services, except Consulting Services and Infrastructure Projects, which may be needed in the transaction of public businesses or in the pursuit of any government undertaking, project or activity, whether in the nature of equipment, furniture, stationery, materials for construction, or personal property of any kind, including non-personal or contractual services such as the repair and maintenance of equipment and furniture, as well as trucking, hauling, janitorial, security, and related or analogous services, as well as procurement of materials and supplies provided by the Procuring Entity for such services. The term “related” or “analogous services” shall include, but is not limited to, lease or purchase of office space, media advertisements, health maintenance services, and other services essential to the operation of the Procuring Entity. (2016 revised IRR, Section 5[r])

GOP – Government of the Philippines.

Infrastructure Projects – Include the construction, improvement, rehabilitation, demolition, repair, restoration or maintenance of roads and bridges, railways, airports, seaports, communication facilities, civil works components of information technology projects, irrigation, flood control and drainage, water supply, sanitation, sewerage and solid waste management systems, shore protection, energy/power and electrification facilities, national buildings, school buildings, hospital buildings, and other related construction projects of the government. Also referred to as *civil works or works*. (2016 revised IRR, Section 5[u])

LGUs – Local Government Units.

NFCC – Net Financial Contracting Capacity.

NGA – National Government Agency.

PCAB – Philippine Contractors Accreditation Board.

PhilGEPS - Philippine Government Electronic Procurement System.

Procurement Project – refers to a specific or identified procurement covering goods, infrastructure project or consulting services. A Procurement Project shall be described, detailed, and scheduled in the Project Procurement Management Plan prepared by the agency which shall be consolidated in the procuring entity's Annual Procurement Plan. (GPPB Circular No. 06-2019 dated 17 July 2019)

PSA – Philippine Statistics Authority.

SEC – Securities and Exchange Commission.

SLCC – Single Largest Completed Contract.

UN – United Nations.

Section I. Invitation to Bid



Republic of the Philippines
Province of Ilocos Norte
CITY GOVERNMENT OF BATAC

Invitation to Bid for the CONSTRUCTION OF BOX CULVERT / RC PIPE CULVERT AT BARANGAY PARANGOPONG

1. The *City Government of Batac*, through the *APPROPRIATION ORDINANCE 6SP 2024-01-SUPPLEMENTAL BUDGET NO. 01 CY 2024 – SPECIAL PURPOSE APPROPRIATION – R.A. 7171 – FY 2020 – LBM 86* intends to apply the sum of **One Million Nine Hundred Ninety-Six Thousand One Hundred Ninety-nine and Seven Centavos (1,996,199.07)** being the Approved Budget for the Contract (ABC) to payments under the contract for **CONSTRUCTION OF BOX CULVERT / RC PIPE CULVERT AT BARANGAY PARANGOPONG** with *Project Identification Number: CGB-2025-PB-01-015*. Bids received in excess of the ABC shall be automatically rejected at bid opening.
2. The *City Government of Batac* now invites bids for the above Procurement Project. Completion of the Works is required **Fifty-two (52) calendar days**. Bidders should have completed a contract similar to the Project. The description of an eligible bidder is contained in the Bidding Documents, particularly, in Section II (Instructions to Bidders).
3. Bidding will be conducted through open competitive bidding procedures using non-discretionary “*pass/fail*” criterion as specified in the 2016 revised Implementing Rules and Regulations (IRR) of Republic Act (RA) No. 9184.
4. Interested bidders may obtain further information from *City Government of Batac* and inspect the Bidding Documents at the address given below from **8:00am to 5:00pm**.
5. A complete set of Bidding Documents may be acquired by interested bidders on **January 14, 2025 (8:00AM to 5:00 PM) to February 03, 2025 (8:00 AM to 03:30 PM)** from given address and website/s below *and upon payment of the applicable fee for the Bidding Documents, pursuant to the latest Guidelines issued by the GPPB, in the amount of Php 5,000.00*. The Procuring Entity shall allow the bidder to present its proof of payment for the fees in person, by facsimile, or through electronic means.
6. The *City Government of Batac* will hold a Pre-Bid Conference¹ on **January 22, 2025 at 3:30** in the afternoon at the BAC Office, 3rd Floor City Hall Building, which shall be open to prospective bidders.
7. Bids must be duly received by the BAC Secretariat through manual submission at the office address as indicated below on or before **February 03, 2025 at 03:30 PM**. Late bids shall not be accepted.
8. All bids must be accompanied by a bid security in any of the acceptable forms and in the amount stated in **ITB** Clause 16.

¹ May be deleted in case the ABC is less than One Million Pesos (PhP1,000,000) where the Procuring Entity may not hold a pre-bid conference.

9. Bid opening shall be on ***February 03, 2025*** at BAC Office 3rd Floor City Hall Building. Bids will be opened in the presence of the or its authorized representatives (with his/her authorization) who choose to attend the activity.
10. The *City Government of Batac* reserves the right to reject any and all bids, declare a failure of bidding, or not award the contract at any time prior to contract award in accordance with Sections 35.6 and 41 of the 2016 revised Implementing Rules and Regulations (IRR) of RA No. 9184, without thereby incurring any liability to the affected bidder or bidders.
11. For further information, please refer to:

ENGR. MICHELLE G. MANUEL
BAC Secretariat Head - Infrastructure
BAC Office 3rd Floor, City Hall Building
City Government of Batac
Washington Street, Brgy. #1-S Valdez
City of Batac, Ilocos Norte 2906
Email: bacbataccity@gmail.com
Tel.No.: (077) 670-6433

12. You may visit the following websites:

For downloading of Bidding Documents: *you may visit www.batac.gov.ph*

MR. MARLON F. SORIA
HRMO / BAC Chairman

Section II. Instructions to Bidders

1. Scope of Bid

The Procuring Entity, *City Government of Batac* invites Bids for the ***Construction of Box Culvert / RC Pipe Culvert at Barangay Parangopong***, with ***Identification Number: CGB-2025-PB-01-015***.

The Procurement Project (“***Construction of Box Culvert / RC Pipe Culvert at Barangay Parangopong***”) is for the construction of Works, as described in Section VI (Specifications).

2. Funding Information

2.1. The GOP through the source of funding as indicated below in the amount of **Php 2,000,000.00**

2.2. The source of funding is: ***APPROPRIATION ORDINANCE 6SP 2024-01-SUPPLEMENTAL BUDGET NO. 01 CY 2024 – SPECIAL PURPOSE APPROPRIATION – R.A.7171 – FY 2020 – LBM 86***

2.3. Bidding Requirements

The Bidding for the Project shall be governed by all the provisions of RA No. 9184 and its 2016 revised IRR, including its Generic Procurement Manual and associated policies, rules and regulations as the primary source thereof, while the herein clauses shall serve as the secondary source thereof.

Any amendments made to the IRR and other GPPB issuances shall be applicable only to the ongoing posting, advertisement, or invitation to bid by the BAC through the issuance of a supplemental or bid bulletin.

The Bidder, by the act of submitting its Bid, shall be deemed to have inspected the site, determined the general characteristics of the contracted Works and the conditions for this Project, such as the location and the nature of the work; (b) climatic conditions; (c) transportation facilities; (c) nature and condition of the terrain, geological conditions at the site communication facilities, requirements, location and availability of construction aggregates and other materials, labor, water, electric power and access roads; and (d) other factors that may affect the cost, duration and execution or implementation of the contract, project, or work and examine all instructions, forms, terms, and project requirements in the Bidding Documents.

3. Corrupt, Fraudulent, Collusive, Coercive, and Obstructive Practices

The Procuring Entity, as well as the Bidders and Contractors, shall observe the highest standard of ethics during the procurement and execution of the contract. They or through an agent shall not engage in corrupt, fraudulent, collusive, coercive, and obstructive practices defined under Annex “I” of the 2016 revised IRR of RA No. 9184 or other integrity violations in competing for the Project.

4. Eligible Bidders

5.1. Only Bids of Bidders found to be legally, technically, and financially capable will be evaluated.

5.2. The Bidder must have an experience of having completed a Single Largest Completed Contract (SLCC) that is similar to this Project, equivalent to at least fifty percent (50%) of the ABC adjusted, if necessary, by the Bidder to current

prices using the PSA's CPI, except under conditions provided for in Section 23.4.2.4 of the 2016 revised IRR of RA No. 9184.

A contract is considered to be "similar" to the contract to be bid if it has the major categories of work stated in the **BDS**.

- 5.3. For Foreign-funded Procurement, the Procuring Entity and the foreign government/foreign or international financing institution may agree on another track record requirement, as specified in the Bidding Document prepared for this purpose.
- 5.4. The Bidders shall comply with the eligibility criteria under Section 23.4.2 of the 2016 IRR of RA No. 9184.

5. Origin of Associated Goods

There is no restriction on the origin of Goods other than those prohibited by a decision of the UN Security Council taken under Chapter VII of the Charter of the UN.

6. Subcontracts

- 7.1. The Bidder may subcontract portions of the Project to the extent allowed by the Procuring Entity as stated herein, but in no case more than fifty percent (50%) of the Project.

The Procuring Entity has prescribed that:

- a. **Subcontracting is not allowed**

7. Pre-Bid Conference

The Procuring Entity will hold a pre-bid conference for this Project on **January 22, 2025** and/or through videoconferencing/webcasting as indicated in paragraph 6 of the **IB**.

9. Clarification and Amendment of Bidding Documents

Prospective bidders may request for clarification on and/or interpretation of any part of the Bidding Documents. Such requests must be in writing and received by the Procuring Entity, either at its given address or through electronic mail indicated in the **IB**, at least ten (10) calendar days before the deadline set for the submission and receipt of Bids.

10. Documents Comprising the Bid: Eligibility and Technical Components

- 10.1. The first envelope shall contain the eligibility and technical documents of the Bid as specified in **Section IX. Checklist of Technical and Financial Documents**.
- 10.2. If the eligibility requirements or statements, the bids, and all other documents for submission to the BAC are in foreign language other than English, it must be accompanied by a translation in English, which shall be authenticated by the appropriate Philippine foreign service establishment, post, or the equivalent office having jurisdiction over the foreign bidder's affairs in the Philippines. For Contracting Parties to the Apostille Convention, only the translated documents shall be authenticated through an apostille pursuant to GPPB

Resolution No. 13-2019 dated 23 May 2019. The English translation shall govern, for purposes of interpretation of the bid.

- 10.3. A valid PCAB License is required, and in case of joint ventures, a valid special PCAB License, and registration for the type and cost of the contract for this Project. Any additional type of Contractor license or permit shall be indicated in the **BDS**.
- 10.4. A List of Contractor's key personnel (e.g., Project Manager, Project Engineers, Materials Engineers, and Foremen) assigned to the contract to be bid, with their complete qualification and experience data shall be provided. These key personnel must meet the required minimum years of experience set in the **BDS**.
- 10.5. A List of Contractor's major equipment units, which are owned, leased, and/or under purchase agreements, supported by proof of ownership, certification of availability of equipment from the equipment lessor/vendor for the duration of the project, as the case may be, must meet the minimum requirements for the contract set in the **BDS**.

11. Documents Comprising the Bid: Financial Component

- 11.1. The second bid envelope shall contain the financial documents for the Bid as specified in **Section IX. Checklist of Technical and Financial Documents**.
- 11.2. Any bid exceeding the ABC indicated in paragraph 1 of the **IB** shall not be accepted.
- 11.3. For Foreign-funded procurement, a ceiling may be applied to bid prices provided the conditions are met under Section 31.2 of the 2016 revised IRR of RA No. 9184.

12. Alternative Bids

Bidders shall submit offers that comply with the requirements of the Bidding Documents, including the basic technical design as indicated in the drawings and specifications. Unless there is a value engineering clause in the **BDS**, alternative Bids shall not be accepted.

13. Bid Prices

All bid prices for the given scope of work in the Project as awarded shall be considered as fixed prices, and therefore not subject to price escalation during contract implementation, except under extraordinary circumstances as determined by the NEDA and approved by the GPPB pursuant to the revised Guidelines for Contract Price Escalation guidelines.

14. Bid and Payment Currencies

- 14.1. Bid prices may be quoted in the local currency or tradeable currency accepted by the BSP at the discretion of the Bidder. However, for purposes of bid evaluation, Bids denominated in foreign currencies shall be converted to Philippine currency based on the exchange rate as published in the BSP reference rate bulletin on the day of the bid opening.
- 14.2. *Payment of the contract price shall be made in:*

- a. Philippine Pesos.

15. Bid Security

- 15.1. The Bidder shall submit a Bid Securing Declaration or any form of Bid Security in the amount indicated in the **BDS**, which shall be not less than the percentage of the ABC in accordance with the schedule in the **BDS**.
- 15.2. The Bid and bid security shall be valid until *120 days*. Any bid not accompanied by an acceptable bid security shall be rejected by the Procuring Entity as non-responsive.

16. Sealing and Marking of Bids

Each Bidder shall submit one copy of the first and second components of its Bid.

The Procuring Entity may request additional hard copies and/or electronic copies of the Bid. However, failure of the Bidders to comply with the said request shall not be a ground for disqualification.

If the Procuring Entity allows the submission of bids through online submission to the given website or any other electronic means, the Bidder shall submit an electronic copy of its Bid, which must be digitally signed. An electronic copy that cannot be opened or is corrupted shall be considered non-responsive and, thus, automatically disqualified.

17. Deadline for Submission of Bids

The Bidders shall submit on the specified date and time and either at its physical address or through online submission as indicated in paragraph 7 of the **IB**.

18. Opening and Preliminary Examination of Bids

- 18.1. The BAC shall open the Bids in public at the time, on the date, and at the place specified in paragraph 9 of the **IB**. The Bidders' representatives who are present shall sign a register evidencing their attendance. In case videoconferencing, webcasting or other similar technologies will be used, attendance of participants shall likewise be recorded by the BAC Secretariat.

In case the Bids cannot be opened as scheduled due to justifiable reasons, the rescheduling requirements under Section 29 of the 2016 revised IRR of RA No. 9184 shall prevail.

- 18.2. The preliminary examination of Bids shall be governed by Section 30 of the 2016 revised IRR of RA No. 9184.

19. Detailed Evaluation and Comparison of Bids

- 19.1. The Procuring Entity's BAC shall immediately conduct a detailed evaluation of all Bids rated "*passed*" using non-discretionary pass/fail criteria. The BAC shall consider the conditions in the evaluation of Bids under Section 32.2 of 2016 revised IRR of RA No. 9184.
- 19.2. If the Project allows partial bids, all Bids and combinations of Bids as indicated in the **BDS** shall be received by the same deadline and opened and evaluated simultaneously so as to determine the Bid or combination of Bids offering the

lowest calculated cost to the Procuring Entity. Bid Security as required by **ITB** Clause 15 shall be submitted for each contract (lot) separately.

- 19.3. In all cases, the NFCC computation pursuant to Section 23.4.2.6 of the 2016 revised IRR of RA No. 9184 must be sufficient for the total of the ABCs for all the lots participated in by the prospective Bidder.

20. Post Qualification

Within a non-extendible period of five (5) calendar days from receipt by the Bidder of the notice from the BAC that it submitted the Lowest Calculated Bid, the Bidder shall submit its latest income and business tax returns filed and paid through the BIR Electronic Filing and Payment System (eFPS), and other appropriate licenses and permits required by law and stated in the **BDS**.

21. Signing of the Contract

The documents required in Section 37.2 of the 2016 revised IRR of RA No. 9184 shall form part of the Contract. Additional Contract documents are indicated in the **BDS**.

Section III. Bid Data Sheet

Bid Data Sheet

ITB Clause																																																													
5.2	For this purpose, contracts similar to the Project refer to contracts which have the same major categories of work, which shall be: <i>Structural Concrete (Class A) 20.68 MPa (28 days) and Portland Cement Concrete Pavement (Unreinforced)-0.20m thk.</i>																																																												
7.1	<i>Sub-contracting is not allowed.</i>																																																												
10.3	<i>None</i>																																																												
10.4	The key personnel must meet the required minimum years of experience set below:																																																												
	<table border="1" style="width: 100%; border-collapse: collapse;"> <thead> <tr> <th style="text-align: left;"><u>Key Personnel</u></th> <th style="text-align: left;"><u>General Experience</u></th> <th style="text-align: left;"><u>Relevant Experience</u></th> </tr> </thead> <tbody> <tr> <td>Project Engineer</td> <td>General Construction</td> <td>5 years</td> </tr> <tr> <td>Materials Engineer</td> <td>General Construction</td> <td>1 year</td> </tr> <tr> <td>Construction Foreman</td> <td>General Construction</td> <td>5 years</td> </tr> <tr> <td>Skilled Worker</td> <td>General Construction</td> <td>5 years</td> </tr> <tr> <td>Unskilled Laborer</td> <td>General Construction</td> <td>3 years</td> </tr> <tr> <td>Safety Officer II</td> <td>General Construction</td> <td>1 year</td> </tr> </tbody> </table>	<u>Key Personnel</u>	<u>General Experience</u>	<u>Relevant Experience</u>	Project Engineer	General Construction	5 years	Materials Engineer	General Construction	1 year	Construction Foreman	General Construction	5 years	Skilled Worker	General Construction	5 years	Unskilled Laborer	General Construction	3 years	Safety Officer II	General Construction	1 year																																							
<u>Key Personnel</u>	<u>General Experience</u>	<u>Relevant Experience</u>																																																											
Project Engineer	General Construction	5 years																																																											
Materials Engineer	General Construction	1 year																																																											
Construction Foreman	General Construction	5 years																																																											
Skilled Worker	General Construction	5 years																																																											
Unskilled Laborer	General Construction	3 years																																																											
Safety Officer II	General Construction	1 year																																																											
10.5	The minimum major equipment requirements are the following:																																																												
	<table border="1" style="width: 100%; border-collapse: collapse;"> <thead> <tr> <th style="text-align: left;"><u>Equipment</u></th> <th style="text-align: left;"><u>Capacity</u></th> <th style="text-align: left;"><u>Number of Units</u></th> </tr> </thead> <tbody> <tr> <td>Backhoe with pavement breaker</td> <td>0.80 cu.m.</td> <td>1</td> </tr> <tr> <td>Payloader</td> <td>1.50 cu.m.</td> <td>1</td> </tr> <tr> <td>Dump truck</td> <td>12 cu.yd</td> <td>2</td> </tr> <tr> <td>Motorized Road Grader</td> <td>140HP, G701A</td> <td>1</td> </tr> <tr> <td>Water truck/Pump</td> <td>16000 L</td> <td>1</td> </tr> <tr> <td>Vibratory Roller</td> <td>10mt, SD1000DC</td> <td>1</td> </tr> <tr> <td>Transit Mixer</td> <td>5.0 cu.m.</td> <td>2</td> </tr> <tr> <td>Concrete vibrator</td> <td></td> <td>1</td> </tr> <tr> <td>Concrete Batch Plant</td> <td>30 cu.m.</td> <td>1</td> </tr> <tr> <td>Concrete Screeder</td> <td>5.5 hp</td> <td>1</td> </tr> <tr> <td>Concrete saw</td> <td>7.5 hp, 14" blade dia.</td> <td>1</td> </tr> <tr> <td>Bar Cutter</td> <td>Single Phase</td> <td>1</td> </tr> <tr> <td>Joint Sealer Equipment</td> <td></td> <td>1</td> </tr> <tr> <td>Bar Cutter</td> <td></td> <td>1</td> </tr> <tr> <td>Bar Bender</td> <td></td> <td>1</td> </tr> <tr> <td>Cargo Truck</td> <td>9-10mt</td> <td>1</td> </tr> <tr> <td>One Bagger Concrete Mixer</td> <td></td> <td>1</td> </tr> <tr> <td>Concrete Vibrator</td> <td></td> <td>1</td> </tr> <tr> <td>Backhoe</td> <td>0.80 cu.m.(crawler)</td> <td>1</td> </tr> </tbody> </table>	<u>Equipment</u>	<u>Capacity</u>	<u>Number of Units</u>	Backhoe with pavement breaker	0.80 cu.m.	1	Payloader	1.50 cu.m.	1	Dump truck	12 cu.yd	2	Motorized Road Grader	140HP, G701A	1	Water truck/Pump	16000 L	1	Vibratory Roller	10mt, SD1000DC	1	Transit Mixer	5.0 cu.m.	2	Concrete vibrator		1	Concrete Batch Plant	30 cu.m.	1	Concrete Screeder	5.5 hp	1	Concrete saw	7.5 hp, 14" blade dia.	1	Bar Cutter	Single Phase	1	Joint Sealer Equipment		1	Bar Cutter		1	Bar Bender		1	Cargo Truck	9-10mt	1	One Bagger Concrete Mixer		1	Concrete Vibrator		1	Backhoe	0.80 cu.m.(crawler)	1
<u>Equipment</u>	<u>Capacity</u>	<u>Number of Units</u>																																																											
Backhoe with pavement breaker	0.80 cu.m.	1																																																											
Payloader	1.50 cu.m.	1																																																											
Dump truck	12 cu.yd	2																																																											
Motorized Road Grader	140HP, G701A	1																																																											
Water truck/Pump	16000 L	1																																																											
Vibratory Roller	10mt, SD1000DC	1																																																											
Transit Mixer	5.0 cu.m.	2																																																											
Concrete vibrator		1																																																											
Concrete Batch Plant	30 cu.m.	1																																																											
Concrete Screeder	5.5 hp	1																																																											
Concrete saw	7.5 hp, 14" blade dia.	1																																																											
Bar Cutter	Single Phase	1																																																											
Joint Sealer Equipment		1																																																											
Bar Cutter		1																																																											
Bar Bender		1																																																											
Cargo Truck	9-10mt	1																																																											
One Bagger Concrete Mixer		1																																																											
Concrete Vibrator		1																																																											
Backhoe	0.80 cu.m.(crawler)	1																																																											
12	<i>Value Engineering not allowed.</i>																																																												
15.1	The bid security shall be in the form of a Bid Securing Declaration or any of the following forms and amounts: <ul style="list-style-type: none"> a. The amount of not less than 39,923.9814 if bid security is in cash, cashier's/manager's check, bank draft/guarantee or irrevocable letter of credit; b. The amount of not less than 99,809.9535, if bid security is in Surety Bond. 																																																												
19.2	Partial bids are not allowed.																																																												
20	<i>None</i>																																																												

21	Additional contract documents relevant to the Project that may be required by existing laws and/or the Procuring Entity, such as construction schedule and S-curve, manpower schedule, construction methods, equipment utilization schedule, construction safety and health program approved by the DOLE, and other acceptable tools of project scheduling.
----	---

Section IV. General Conditions of Contract

1. Scope of Contract

This Contract shall include all such items, although not specifically mentioned, that can be reasonably inferred as being required for its completion as if such items were expressly mentioned herein. All the provisions of RA No. 9184 and its 2016 revised IRR, including the Generic Procurement Manual, and associated issuances, constitute the primary source for the terms and conditions of the Contract, and thus, applicable in contract implementation. Herein clauses shall serve as the secondary source for the terms and conditions of the Contract.

This is without prejudice to Sections 74.1 and 74.2 of the 2016 revised IRR of RA No. 9184 allowing the GPPB to amend the IRR, which shall be applied to all procurement activities, the advertisement, posting, or invitation of which were issued after the effectivity of the said amendment.

2. Sectional Completion of Works

If sectional completion is specified in the **Special Conditions of Contract (SCC)**, references in the Conditions of Contract to the Works, the Completion Date, and the Intended Completion Date shall apply to any Section of the Works (other than references to the Completion Date and Intended Completion Date for the whole of the Works).

3. Possession of Site

3.1 The Procuring Entity shall give possession of all or parts of the Site to the Contractor based on the schedule of delivery indicated in the **SCC**, which corresponds to the execution of the Works. If the Contractor suffers delay or incurs cost from failure on the part of the Procuring Entity to give possession in accordance with the terms of this clause, the Procuring Entity's Representative shall give the Contractor a Contract Time Extension and certify such sum as fair to cover the cost incurred, which sum shall be paid by Procuring Entity.

3.2 If possession of a portion is not given by the above date, the Procuring Entity will be deemed to have delayed the start of the relevant activities. The resulting adjustments in contract time to address such delay may be addressed through contract extension provided under Annex "E" of the 2016 revised IRR of RA No. 9184.

4. The Contractor's Obligations

The Contractor shall employ the key personnel named in the Schedule of Key Personnel indicating their designation, in accordance with **ITB** Clause 10.3 and specified in the **BDS**, to carry out the supervision of the Works.

The Procuring Entity will approve any proposed replacement of key personnel only if their relevant qualifications and abilities are equal to or better than those of the personnel listed in the Schedule.

5. Performance Security

5.1. Within ten (10) calendar days from receipt of the Notice of Award from the Procuring Entity but in no case later than the signing of the contract by both parties, the successful Bidder shall furnish the performance security in any of the forms prescribed in Section 39 of the 2016 revised IRR.

- 5.2. The Contractor, by entering into the Contract with the Procuring Entity, acknowledges the right of the Procuring Entity to institute action pursuant to RA No. 3688 against any subcontractor be they an individual, firm, partnership, corporation, or association supplying the Contractor with labor, materials and/or equipment for the performance of this Contract.

6. Site Investigation Reports

The Contractor, in preparing the Bid, shall rely on any Site Investigation Reports referred to in the **SCC** supplemented by any information obtained by the Contractor.

7. Warranty

- 7.1. In case the Contractor fails to undertake the repair works under Section 62.2.2 of the 2016 revised IRR, the Procuring Entity shall forfeit its performance security, subject its property(ies) to attachment or garnishment proceedings, and perpetually disqualify it from participating in any public bidding. All payables of the GOP in his favor shall be offset to recover the costs.
- 7.2. The warranty against Structural Defects/Failures, except that occasioned-on force majeure, shall cover the period from the date of issuance of the Certificate of Final Acceptance by the Procuring Entity. Specific duration of the warranty is found in the **SCC**.

8. Liability of the Contractor

Subject to additional provisions, if any, set forth in the **SCC**, the Contractor's liability under this Contract shall be as provided by the laws of the Republic of the Philippines.

If the Contractor is a joint venture, all partners to the joint venture shall be jointly and severally liable to the Procuring Entity.

9. Termination for Other Causes

Contract termination shall be initiated in case it is determined *prima facie* by the Procuring Entity that the Contractor has engaged, before, or during the implementation of the contract, in unlawful deeds and behaviors relative to contract acquisition and implementation, such as, but not limited to corrupt, fraudulent, collusive, coercive, and obstructive practices as stated in **ITB** Clause 4.

10. Dayworks

Subject to the guidelines on Variation Order in Annex "E" of the 2016 revised IRR of RA No. 9184, and if applicable as indicated in the **SCC**, the Dayworks rates in the Contractor's Bid shall be used for small additional amounts of work only when the Procuring Entity's Representative has given written instructions in advance for additional work to be paid for in that way.

11. Program of Work

- 11.1. The Contractor shall submit to the Procuring Entity's Representative for approval the said Program of Work showing the general methods, arrangements, order, and timing for all the activities in the Works. The submissions of the Program of Work are indicated in the **SCC**.
- 11.2. The Contractor shall submit to the Procuring Entity's Representative for approval an updated Program of Work at intervals no longer than the period stated in the **SCC**. If the Contractor does not submit an updated Program of Work within this period, the Procuring Entity's Representative may withhold

the amount stated in the **SCC** from the next payment certificate and continue to withhold this amount until the next payment after the date on which the overdue Program of Work has been submitted.

12. Instructions, Inspections and Audits

The Contractor shall permit the GOP or the Procuring Entity to inspect the Contractor's accounts and records relating to the performance of the Contractor and to have them audited by auditors of the GOP or the Procuring Entity, as may be required.

13. Advance Payment

The Procuring Entity shall, upon a written request of the Contractor which shall be submitted as a Contract document, make an advance payment to the Contractor in an amount not exceeding fifteen percent (15%) of the total contract price, to be made in lump sum, or at the most two installments according to a schedule specified in the **SCC**, subject to the requirements in Annex "E" of the 2016 revised IRR of RA No. 9184.

14. Progress Payments

The Contractor may submit a request for payment for Work accomplished. Such requests for payment shall be verified and certified by the Procuring Entity's Representative/Project Engineer. Except as otherwise stipulated in the **SCC**, materials and equipment delivered on the site but not completely put in place shall not be included for payment.

15. Operating and Maintenance Manuals

15.1. If required, the Contractor will provide "as built" Drawings and/or operating and maintenance manuals as specified in the **SCC**.

15.2. If the Contractor does not provide the Drawings and/or manuals by the dates stated above, or they do not receive the Procuring Entity's Representative's approval, the Procuring Entity's Representative may withhold the amount stated in the **SCC** from payments due to the Contractor.

Section V. Special Conditions of Contract

Special Conditions of Contract

GCC Clause	
2	<i>The intended completion date is Fifty-Two (52) calendar days from the Effective Date of the Contract.</i>
4.1	N/A
6	N/A
7.2	Five (5) years.
10	Dayworks are applicable at the rate shown in the Contractor's original Bid.
11.1	The Contractor shall submit the Program of Work to the Procuring Entity's Representative within <i>Seven (7)</i> days of delivery of the Notice of Award.
11.2	N/A
13	The amount of the advance payment <i>shall not exceed 15% of the total contract price and schedule of payment.</i>
14	<i>Not Allowed</i>
15.1	N/A
15.2	N/A

Section VI. Specifications

SECTION VI

GENERAL SPECIFICATIONS

PROJECT: INSTALLATION/CONSTRUCTION OF CROSS DRAINAGE-CONSTRUCTION OF BOX CULVERT/RC PIPE CULVERT AT BARANGAY PARANGOPONG
LOCATION: BRGY. PARANGOPONG, CITY OF BATAC, ILOCOS NORTE

1. General Requirements

- 1.1 The intent of this contract is to construct a triple barrel box culvert located at Brgy. Parangopong, City of Batac.
- 1.2 The contractor will furnish the engineering drawings, the BOQs of the specific structures and shall post a Supervising Engineer to monitor the overall progress of works, and ensure that standards, specifications and quality workmanship are applied.
- 1.3 The Contractor is responsible for the following tasks:
 - . site preparation
 - . supply of materials and equipment
 - . construction of specified works as per Drawings and the BOQ
- 1.4 The work is taken together as a whole and any item required to interface or is implied by the separate items of work as listed shall be supplied by the contractor to deliver a complete and functional facility.
- 1.5 The contractor will not allow any worker on the site who is below 16-years old. The Contractor must ensure that all workers hired for the project are above this age.

2. Standard References

- 2.1 The contractor shall follow and apply the standards and specifications as listed in the engineering drawings and the BOQ specifications; any need for further clarification shall be addressed to the Chief Technical Advisor (CTA/City Engineer) through the Supervising Engineer on site.
- 2.2 The materials and equipment provided shall be new, good quality and of known origin. All inputs to project must be inspected by the Supervising Engineer who in consultation with the CTA may reject any item that does not meet standards and specifications.
- 2.3 The contractor will maintain a safe and clean site during all phases of construction, and maintained records of materials, labor, weather and progress.
- 2.4 All accumulated trash must be kept in bins at the site, and must be removed at regular intervals.
- 2.5 The contractor will be responsible for security of materials and equipment at site throughout the construction phases. Removal of such from site for any reason must be cleared through the Supervising Engineer, first.
- 2.6 The contractor shall warrant all materials and equipment and workmanship to be free of defects under normal service and use for a period of 6 months after acceptance of substantial completion of works.

3. Site Clearance and work

a. Pre-Construction

- 3.1 The contractor shall survey the site in order to verify existing conditions of any aboveground facilities and underground utilities of the project site.
- 3.2 Clear and grub the site as needed and approved by the Supervising Engineer.
- 3.3 Remove all trash, debris and demolition products from the site to a designated disposal area.



3.4 Furnish and install the appropriate safety signs, barricades and directions.

3.5 No work will take place until the Contractor has submitted and the CTA has approved the contractor's plan of work, and the safety plan reflecting the requirements of the project.

b. Post-Construction

3.8 Following completion of construction works, the contractor must remove and clear all debris and trash from materials at the site, and clear the site to standards as instructed by the Engineer.

3.9 The Engineer will identify suitable location for placing any excess soil (a result of the excavations) and of any remains of construction materials.

4. Safety and Protective Equipment

4.1 The Contractor shall be responsible for the personal safety requirements of its personnel that include but is not limited to the provision of the following minimum requirements.

- . Safety helmets (hard hats)
- . Close-toed footwear
- . Safety glasses (goggles) when performing tasks requiring eye and face protection
- . Work-gloves

5. Concrete and Aggregates

5.1 Cement - Unless otherwise specified cement shall be ordinary Portland cement meeting the 28 days compressive strength of 25MPa (3626 psi) requirement.

5.2 City Project Engineer shall facilitate the contractor, if needed, for the purchase of cement from the supplier. The contractor shall be responsible for payment and transport of cement to the site.

5.3 The contractor is responsible for cement storage in dry and secure location within the project sites. Damaged or partly set cement will not be allowed to be used and must be removed from the site.

5.4 All concrete sampling and testing shall be performed in accordance with American Concrete Institute Standards (BS 8110).

5.5 All concrete shall be consolidated by vibratory compaction tool of appropriate size and shape.

5.6 No hand-field mixing of concrete will be allowed; all concrete must be machine mixed.

5.7 Rebars shall be embedded a minimum of 1½" from surface.

5.8 Installation of rebars must be strong and solid and must be approved by the Supervising Engineer before pouring concrete.

5.9 Curing of concrete must be done by covering with burlap saturated with water for a minimum of 4 days.

5.10 All fine and coarse aggregates proposed for use in the project shall be approved by the Engineer prior to any use. As defined in ASTM C33, which refers to proportions of aggregates, concrete is stronger and more structurally effective when all particles in the mix are well graded in size.

5.11 The coarse aggregate (gravel) should be rough and clean with broken faces; rounded particles will not adhere well in the mixture and must be avoided. Dirt and organics in the mix will also decrease strength, and any aggregate containing soil must be washed until clean.

5.12 Maximum gravel size is always 3 inches but should be used only in specific works as guided by the engineer. Aggregates larger than 2 inches will usually reduce concrete strength. Maximum aggregate size must be less than:

- . 0.2 times narrowest dimension between form walls
- . 0.33 times depth of slab
- . 0.75 times the distance from rebar to the exposed surface

SPW

5.13 Sand size should also be graded. It shall be clean and free from impurities. If sand is collected from the beach, it must be washed with fresh water. River sand is preferred but it must be checked for any soil, silt content.

5.14 WATER:

The water use for concrete must be clean, and of "potable" quality if possible. In no case dirty or salty water should be used in a concrete or mortar mix. Also, no water from swamps or ponds should be used as it may contain organic matter.

5.15 The amount of water to be used should be about 50% of the volume of cement. If necessary, in order to determine the workability of concrete a slump test should be performed.

6. Preparations and guidelines

6.1 Preparation prior to concrete placement, final inspection and approval and formwork:

Before the concrete is actually placed in position the interior of formwork shall be inspected to see that they have been cleaned and oiled. Formwork shall be timber, plywood, or metal. Formwork work shall conform to the shapes, lines and dimensions as shown on the drawings. Formwork shall be strong enough to withstand concrete vibration. The timber used as formwork shall be well seasoned and free from sap (wood fluid), worm's holes, warps or other surface defects.

6.2 Concrete Mixing:

Each batch shall be mixed until the concrete is uniform in color for a minimum period of 2 minutes after all ingredients are in the drum when using concrete mixer. Each time the work stops the mixer shall be cleaned out and when next commencing the mixing the first batch of concrete shall have 10% additional cement to allow for sticking in the drum. Otherwise, where manual labor is required, mixing including all ingredients should last for a minimum period of 5 minutes.

6.3 Admixture:

If the need arises to use Calcium Chloride, such as in mass concrete works, it shall be dissolved in water and added to the mixing water in an amount not to exceed 1.5 percent of the weight of cement in each batch of concrete. Admixture shall be used in accordance with the manufacturer's instructions and in control with the Engineer.

6.6 Contaminated Concrete:

Concrete which has become stiff or has been contaminated with foreign materials and which has not been placed in half an hour of mixing water with cement shall be rejected and disposed off as directed by the Engineer.

6.7 Handling of equipment after mixing concrete:

All equipment used for mixing concrete shall be maintained in clean condition after every use of concrete placement.

6.8 Curing of concrete:

Adequate curing is vital to quality concrete. In all applications, care needs to be taken to properly cure concrete, and achieve best strength and hardness. This happens after the concrete has been placed. Cement requires a moist, controlled environment to gain strength and harden fully. The cement paste hardens over time, initially setting and becoming rigid though very weak, and gaining in strength in the weeks following. The concrete must be kept moist for minimum 7 days to maximum 21 days depending on the ambient temperatures. Temperatures above 20 °C tend to cause drying out at too fast rate. Therefore, the concrete must be kept moist using wetted burlap for at least 72 hours. In around 3 weeks, over 90% of the final strength is typically reached, though it may continue to strengthen for decades. Abnormally fast drying and shrinkage due to factors such as evaporation from hot weather temperatures and wind during placement may lead to increased tensile stresses at a time when it has not yet gained significant strength, resulting in greater shrinkage cracking. The early strength of the concrete can be increased by keeping it damp for the period specified above during the curing process. Minimizing stress of concrete prior to curing minimizes cracking. Improper curing can cause scaling, reduced strength, poor abrasion resistance, and cracking.

6.9 Steel reinforcement:

Ribbed reinforcing steel (rebar) shall be of good quality and have the approval of the Engineer prior to use. All rebar specified in the drawings must be bent as per bending schedule. Wire mesh (commonly called 'BRC') may replace rebar if approved by the Engineer. The contractor must take measures for storage of rebar for prevention from corrosion. All rebar shall be clean, free from grease, oil, paint, or any other material that will destroy or reduce the bond.

7.0 Variation Orders

The Engineer may issue to the Contractor, if necessary, a change order for substitution or modification or cancellation of materials or works in the design of the project and/or the BOQ of the project. The Contractor shall be informed and guided accordingly verbally and in written form. Any required adjustments in terms of payments it must be specified in advance to the contractor and agreed in writing. The contractor must ensure that any change of works is acknowledged and documented in writing.

8.0 Compensation for Additional Works

Should the contractor identify, in the progress of works, that additional work or quantities of materials have been necessary, he must bring it to the attention of the Engineer and received approval, verbal and in writing, prior to proceeding with such exercise. The Engineer shall process any adjustment needed in the BOQ, accordingly, and issue a letter with details to the contractor.

9.0 Payments and submission procedure

Contract is based on a BOQ procedure; i.e. all payments due to the contractor is based on executed works as per BOQ quantities and pricing. The contractor must prepare as per BOQ format the amounts and sections of executed works on a monthly basis. The Supervising Engineer must check, verify that the submitted quantities are correct and signed the BOQ format as truly reflecting the actual works carried out during the month. The contractor, at no time is permitted to alter the original format of the BOQ; if this happens, the documentation submitted will not be accepted.

Prepared by:

ZHERLAND F. REBUCAL
Engineer II 

Section VII. Drawings

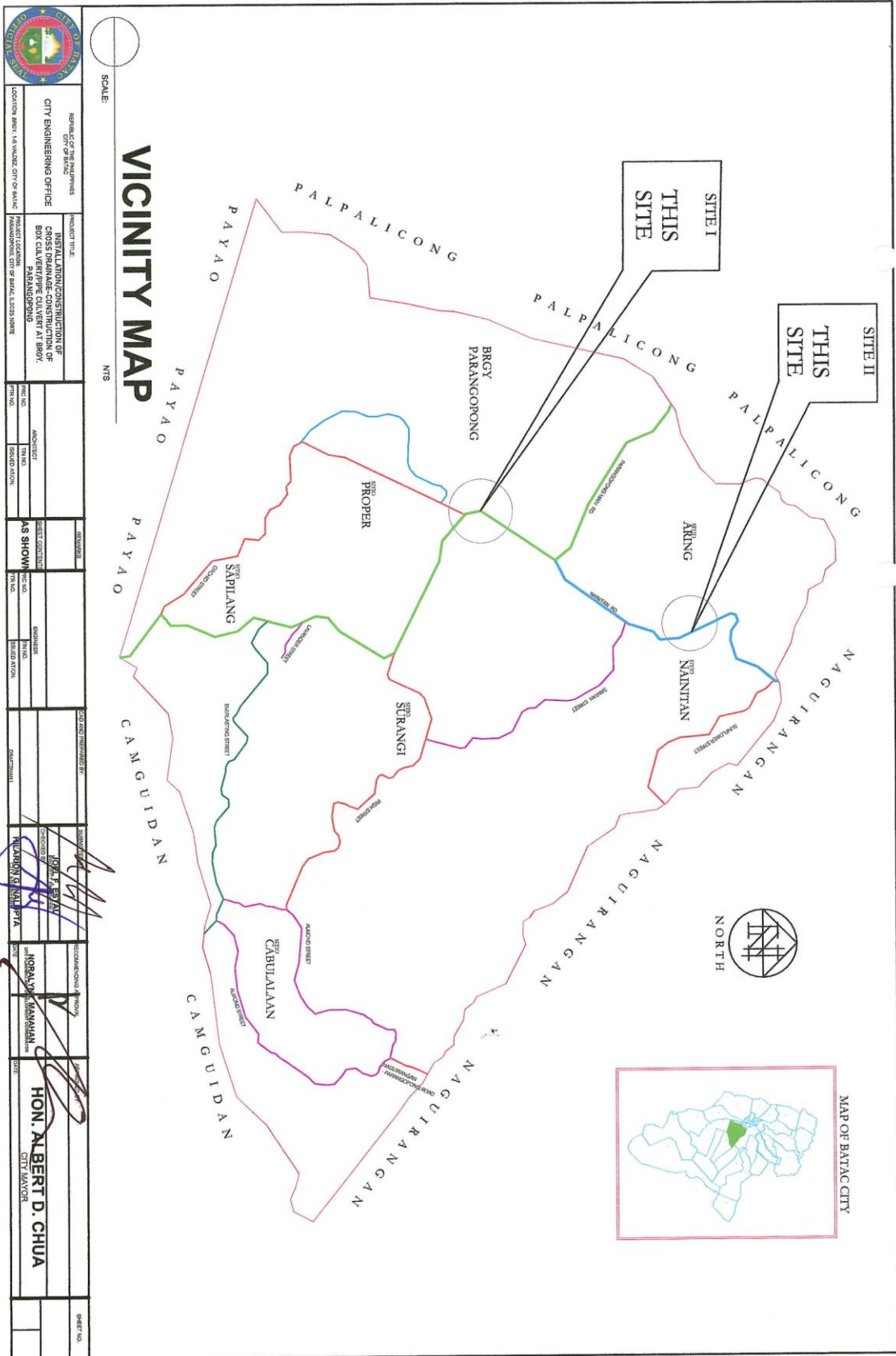

VICINITY MAP

SCALE: NTS

		PROJECT TITLE INSTALLATION/CONSTRUCTION OF BOX CULVERT/PIPE CULVERT AT BRGY. PARANGOPONG		PROJECT LOCATION PARANGOPONG BRGY., BATAAC CITY	
APPROVED BY: CITY ENGINEERING OFFICE		DATE: AS SHOWN		APPROVED BY: HON. ALBERT D. CHUA CITY LANCER	
PROJECT LOCATION PARANGOPONG BRGY., BATAAC CITY		DATE: AS SHOWN		APPROVED BY: HON. ALBERT D. CHUA CITY LANCER	

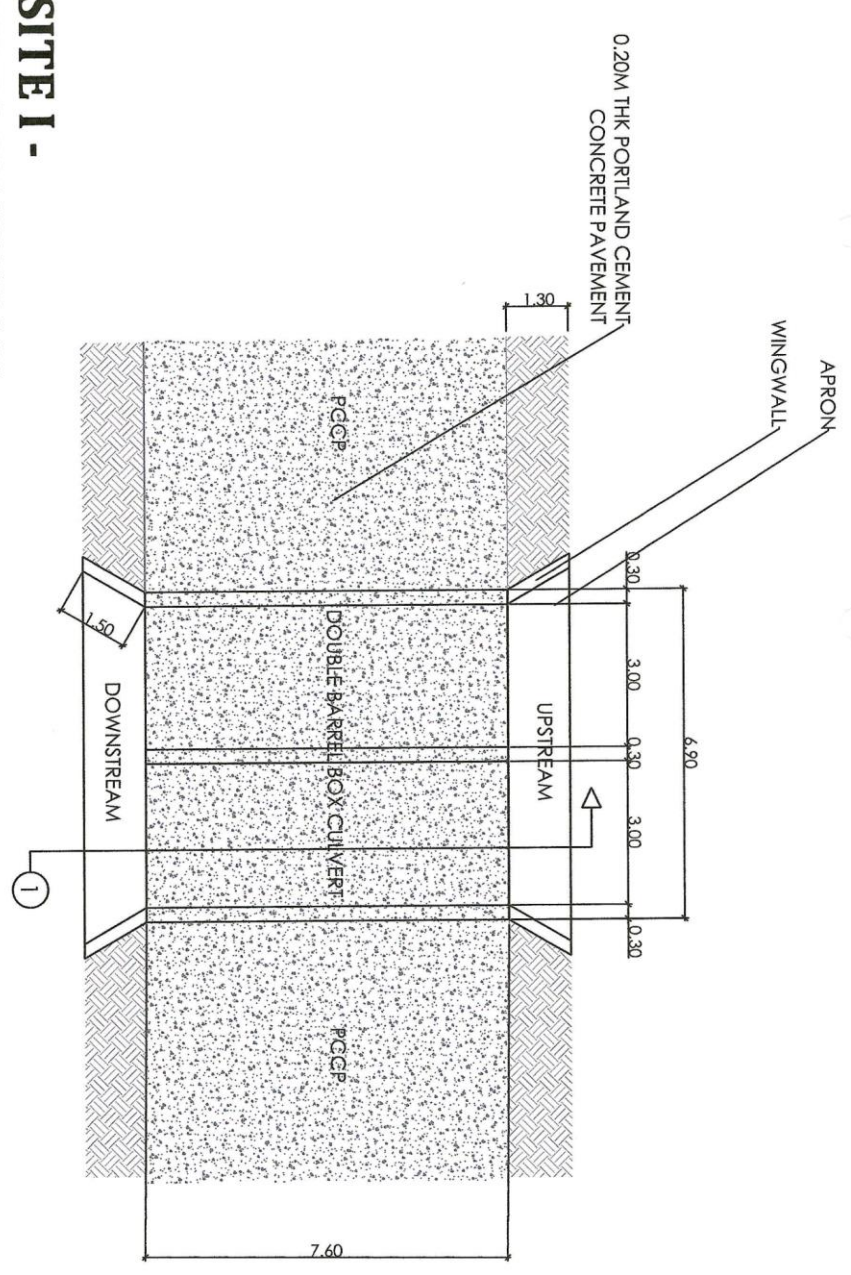

**SITE I -
SITIO NAINITAN**

PLAN
SCALE: _____ NTS

		REPUBLIC OF THE PHILIPPINES CITY OF PASIG CITY ENGINEERING OFFICE PROJECT TITLE: CONSTRUCTION OF CONCRETE BOX CULVERT/PIPE CULVERT AT BRNO, PARANGPODPOD PROJECT LOCATION: BRNO, PASIG CITY LOCATION: BRNO 14 WALKER CITY OF PASIG	
PROJECT NO. DRAWING NO. SHEET NO.	PROJECT TITLE PROJECT LOCATION LOCATION	DESIGNED BY CHECKED BY AS SHOWN DATE	APPROVED BY HON. ALBERT D. CHUA CITY MANOR
DATE OF ISSUE DATE OF REVISION	NO. OF SHEETS NO. OF SHEETS USED	DRAWING NO. SHEET NO. DATE	SHEET NO.

SITE II - SITIO PROPER

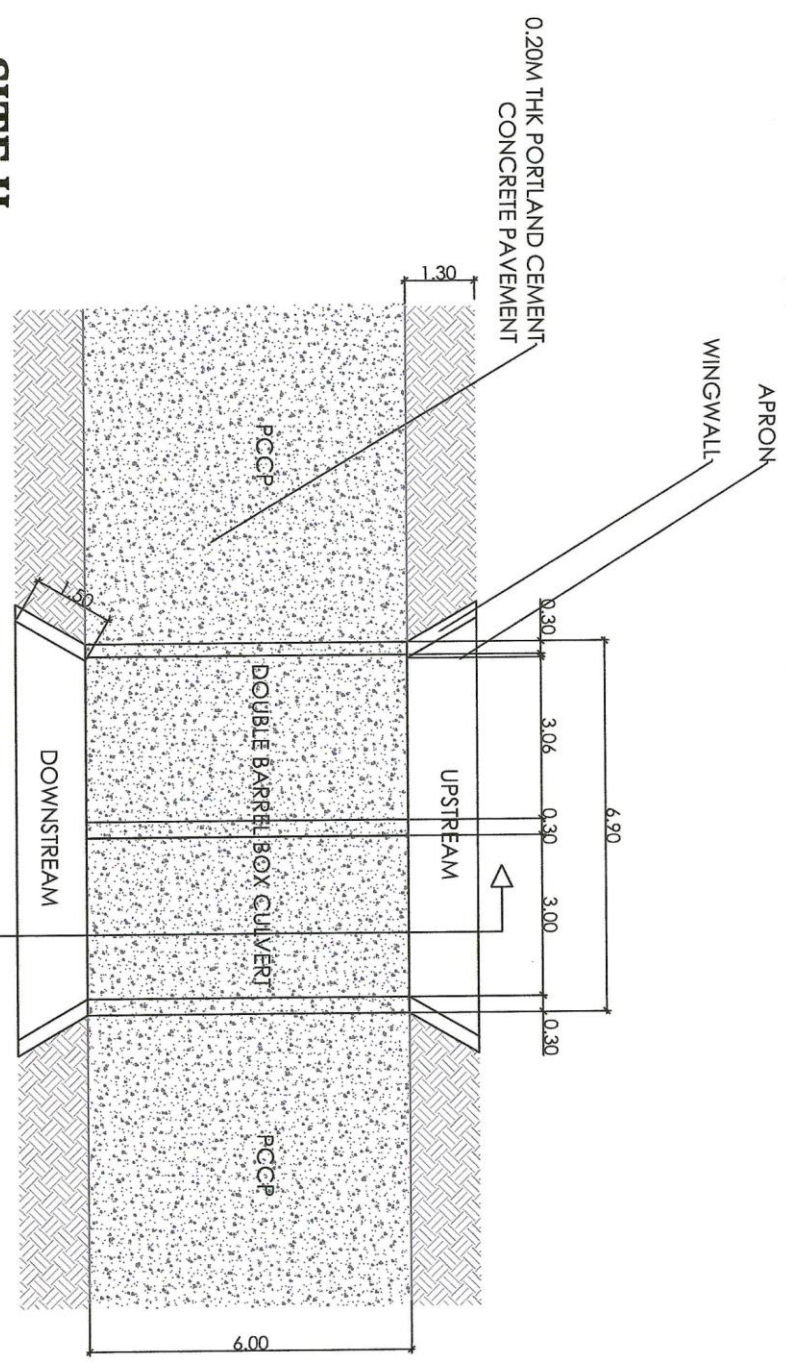

PLAN
SCALE: 1 NTS

		REPUBLIC OF THE PHILIPPINES CITY OF MANILA CITY ENGINEERING OFFICE		PROJECT TITLE INSTALLATION/CONSTRUCTION OF BOX CULVERT/PIPE CULVERT AT BRNO, PARANGORONG		PROJECT LOCATION BRNO, CITY OF MANILA		SHEET NO. AS SHOWN		APPROVED BY HON. ALBERT D. CHUA CITY MANOR	
LOCATION BRNO, 1-8 WALDE CITY OF MANILA		PROJECT NO. BRNO-2023-001		SHEET NO. AS SHOWN		SHEET NO. AS SHOWN		SHEET NO. AS SHOWN		SHEET NO. AS SHOWN	

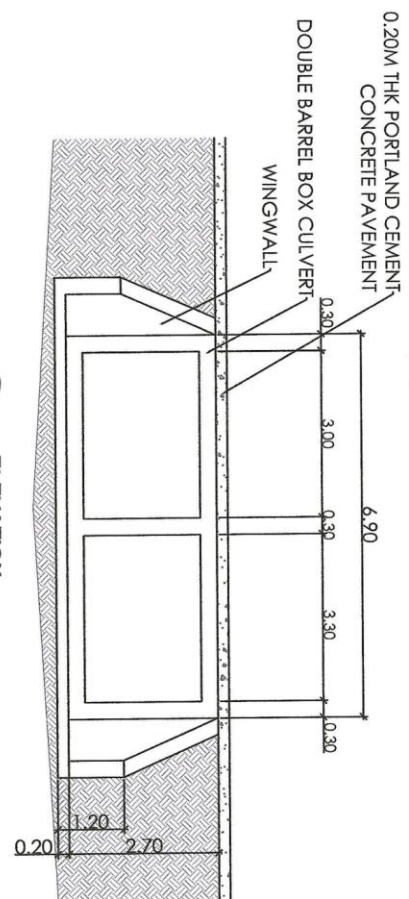

ELEVATION
SCALE NTS

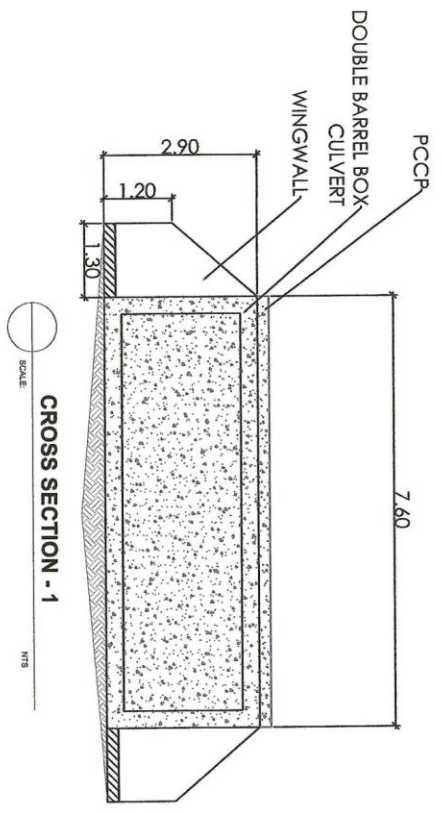

CROSS SECTION - 1
SCALE NTS

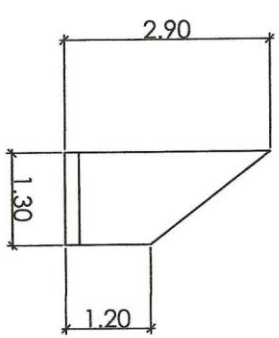

SECTION - WINGWALL
SCALE NTS

		REPUBLIC OF THE PHILIPPINES CITY OF MANILA CITY ENGINEERING OFFICE		PROJECT TITLE INSTALLATION/CONSTRUCTION OF BOX CULVERT/PIPE CULVERT AT BRNO/ PARANGPONDING		PROJECT LOCATION BRNO, PARANGPONDING		LOCATION MAP 1:4 SCALE CITY OF MANILA	
DESIGNED BY	CHECKED BY	APPROVED BY	DATE	DESIGNED BY	CHECKED BY	APPROVED BY	DATE	DESIGNED BY	CHECKED BY
AS SHOWN	AS SHOWN	HON. ALBERT D. CHUA							
HON. ALBERT D. CHUA CITY MANOR		SHEET NO.							

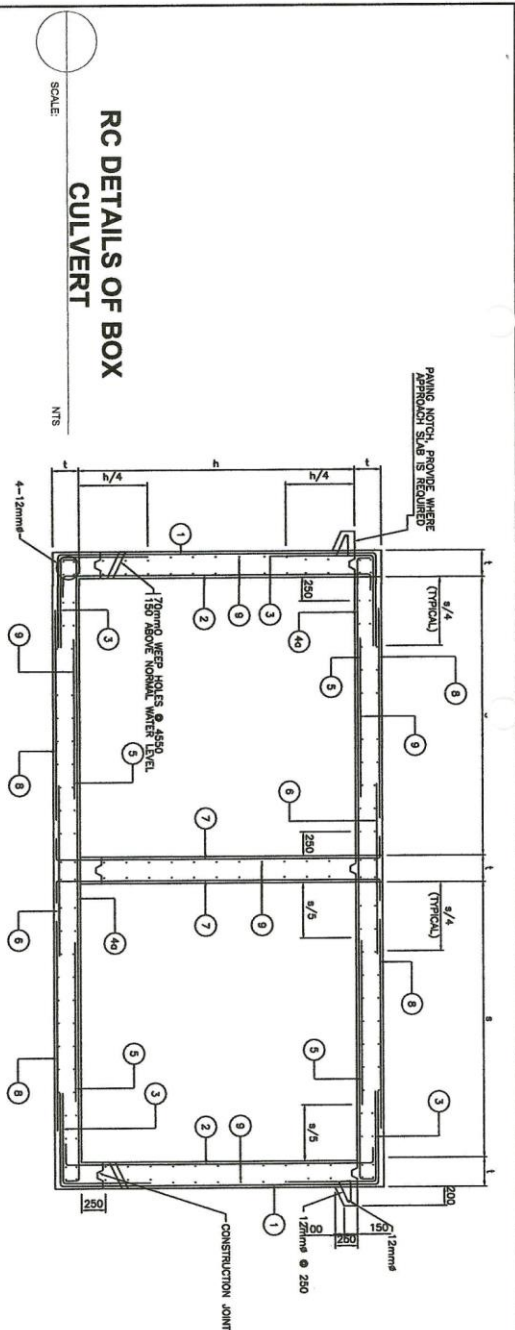

RC DETAILS OF BOX CULVERT

SCALE

NTS

CLEAR SPAN s	HEIGHT h	SINGLE BARREL BOX CULVERT						DOUBLE AND TRIPLE BARREL BOX CULVERT									
		BAR 1	BAR 2	BAR 3	BAR 4	BAR 5	BAR 6	BAR 1	BAR 2	BAR 3	BAR 4	BAR 5	BAR 6	BAR 7	BAR 8	BAR 9	
		t	Ø SPACING	Ø SPACING	Ø SPACING	Ø SPACING	Ø SPACING	t	Ø SPACING	Ø SPACING	Ø SPACING	Ø SPACING	Ø SPACING	Ø SPACING	Ø SPACING	Ø SPACING	
	2100	280 16	260 16	260 16	260 16	260 16	260 16	300 20	300 16	280 20	20 300	20 300	20 300	25 170	12 300	12 200	12 250
	2400	280 16	260 16	260 16	260 16	260 16	260 16	300 20	300 16	280 20	20 300	20 300	20 300	25 170	12 300	12 200	12 250
	2750	280 16	260 16	240 16	220 16	200 12	200 12	300 20	300 16	200 20	20 300	20 300	20 300	25 170	16 300	12 200	12 250
3000	3000	280 16	200 16	220 16	200 16	200 12	250 12	300 20	300 16	200 20	20 300	20 300	25 170	16 300	12 200	12 250	

BAR SCHEDULE

SCALE

NTS

		REPUBLIC OF THE PHILIPPINES CITY OF MANILA		PROJECT TITLE INSTALLATION/CONSTRUCTION OF CROSS BRIDGE-CONSTRUCTION OF BOX CULVERT/PIPE CULVERT AT BHWY. PARANGPANG		SHEET NO.	
CITY ENGINEERING OFFICE		PREPARED BY: MANABANG, CITY OF MANILA, ALDOY VENTE		CHECKED BY: AS SHOWN		APPROVED BY: HON. ALBERT D. CHUA CITY MANOR	
LOCATION: BHWY. 14 VALDEZ, CITY OF MANILA		DRAWING NO.		DATE		SHEET NO.	

Section VIII. Bill of Quantities

Section VIII. Bill of Quantities

ITEM	DESCRIPTION	UNIT	QUANTITY	UNIT PRICE (Pesos)	AMOUNT PESOS
B.5	Project Billboard/ Signboard	Ea.	1.00	<u>In words:</u> <u>In Figures:</u>	In Figures:
B.7(1)	Occupational Safety and Health Program	l.s.	1.00	<u>In words:</u> <u>In Figures:</u>	In Figures:
B.9	Mobilization / Demobilization	l.s	1.00	<u>In words:</u> <u>In Figures:</u>	In Figures:
101(1)	Removal of actual structures/obstruction	l.s.	1.00	<u>In words:</u> <u>In Figures:</u>	In Figures:
200(1)	Aggregate Subbase Course	Cu. m.	19.72	<u>In words:</u> <u>In Figures:</u>	In Figures:
311(1)b1	Portland Cement Concrete Pavement (Unreinforced) – 0.20 m thk.	Sq. m.	197.20	<u>In words:</u> <u>In Figures:</u>	In Figures:
1702(1)a	Structure Excavation (Soft Rock)	Cu.m.	40.56	<u>In words:</u> <u>In Figures:</u>	In Figures:
1704(1)	Embankment from Selected Borrow	Cu.m.	40.56	<u>In words:</u> <u>In Figures:</u>	In Figures:
404(1)a	Reinforcing Steel, Grade 40	Kgs.	9,623.72	<u>In words:</u> <u>In Figures:</u>	In Figures:
405(1)a3	Structural Concrete (ClassA) 20.68 MPa (28 days)	Cu.m	89.30	<u>In words:</u> <u>In Figures:</u>	In Figures:

Section IX. Checklist of Technical and Financial Documents

Checklist of Technical and Financial Documents

I. TECHNICAL COMPONENT ENVELOPE

Class “A” Documents

Legal Documents

- (a) Valid PhilGEPS Registration Certificate (Platinum Membership) (all pages);
or

Technical Documents

- (e) Statement of the prospective bidder of all its ongoing government and private contracts, including contracts awarded but not yet started, if any, whether similar or not similar in nature and complexity to the contract to be bid; **and**
- (f) Statement of the bidder’s Single Largest Completed Contract (SLCC) similar to the contract to be bid, except under conditions provided under the rules; **and**
- (g) Philippine Contractors Accreditation Board (PCAB) License;
or
Special PCAB License in case of Joint Ventures;
and registration for the type and cost of the contract to be bid; **and**
- (h) Original copy of Bid Security. If in the form of a Surety Bond, submit also a certification issued by the Insurance Commission;
or
Original copy of Notarized Bid Securing Declaration; **and**
- (i) Project Requirements, which shall include the following:
- a. Organizational chart for the contract to be bid;
- b. List of contractor’s key personnel (*e.g.*, Project Manager, Project Engineers, Materials Engineers, and Foremen), to be assigned to the contract to be bid, with their complete qualification and experience data;
- c. List of contractor’s major equipment units, which are owned, leased, and/or under purchase agreements, supported by proof of ownership or certification of availability of equipment from the equipment lessor/vendor for the duration of the project, as the case may be; **and**
- (j) Original duly signed Omnibus Sworn Statement (OSS);
and if applicable, Original Notarized Secretary’s Certificate in case of a corporation, partnership, or cooperative; or Original Special Power of Attorney of all members of the joint venture giving full power and authority to its officer to sign the OSS and do acts to represent the Bidder.

Financial Documents

- (k) The prospective bidder’s audited financial statements, showing, among others, the prospective bidder’s total and current assets and liabilities, stamped “received” by the BIR or its duly accredited and authorized institutions, for the preceding calendar year which should not be earlier than two (2) years from the date of bid submission; **and**
- (l) The prospective bidder’s computation of Net Financial Contracting Capacity (NFCC).

Class “B” Documents

- (m) If applicable, duly signed joint venture agreement (JVA) in accordance with RA No. 4566 and its IRR in case the joint venture is already in existence;
or

duly notarized statements from all the potential joint venture partners stating that they will enter into and abide by the provisions of the JVA in the instance that the bid is successful.

II. FINANCIAL COMPONENT ENVELOPE

- (n) Original of duly signed and accomplished Financial Bid Form; **and**

Other documentary requirements under RA No. 9184

- (o) Original of duly signed Bid Prices in the Bill of Quantities; **and**
- (p) Duly accomplished Detailed Estimates Form, including a summary sheet indicating the unit prices of construction materials, labor rates, and equipment rentals used in coming up with the Bid; **and**
- (q) Cash Flow by Quarter.

